

# Heavy Duty Spring Latch Series 779

*Design locks open and locks closed*

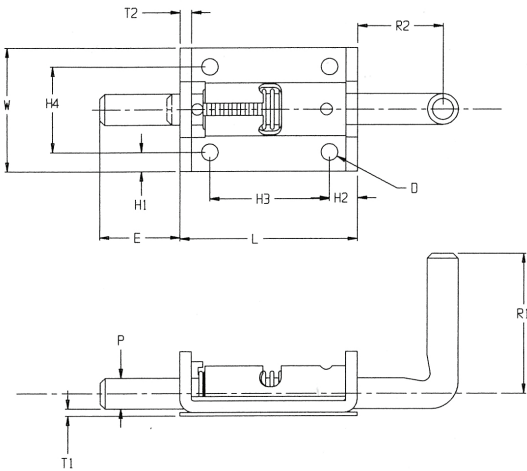

Paneloc heavy-duty spring latches are available in 3/8" and 1/2" pin diameters. These large, rugged latches are available in steel or stainless steel and have a closed knuckle for added durability and strength.

## PIN

P	Pin Diameter	.50
* E	Extension	1.31

## BODY

* L	Length	2.00
W	Width	.500
T1	Thickness	.12
T2	Thickness	.19
R1	Handle Length	2.50
R2	Handle Extension	1.38
H1	Hole Location	.31
H2	Hole Location	.45
H3	Hole Location	1.937
H3	Hole Location	1.380
* D	Hole Diameter	.27

## MATERIALS

Designation: C = Stainless S = Steel

## FINISH

Most commercial finishes are available, including zinc and cadmium on steel, passivate and electropolishing on stainless steel.

## ORDERING INFORMATION

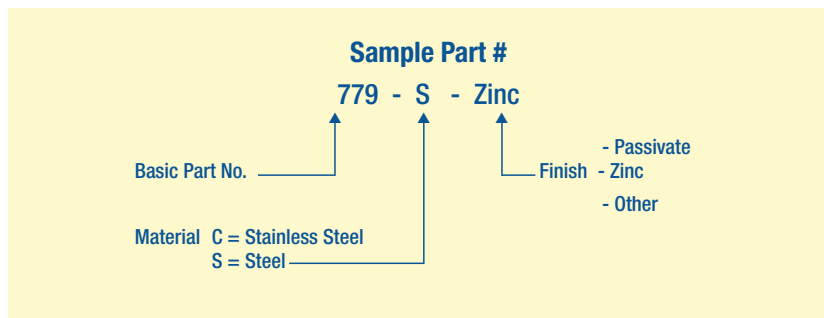

#779 Design locks open, and locks closed.