

## Hasps and Staples

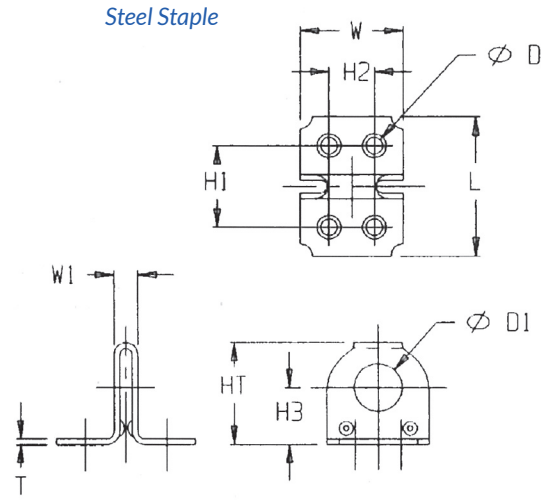
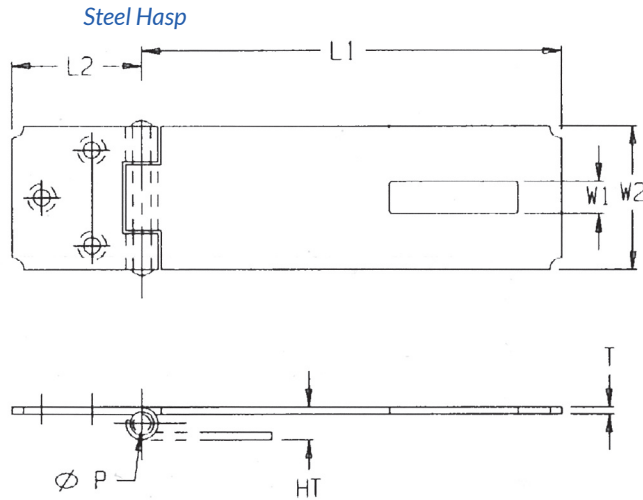

STAPLES	LENGTH	WIDTH	HEIGHT	W1	THICKNESS	HOLE
#110	1.00	.69	.72	.19	.040	#6 SCREW
#115	1.44	1.06	1.06	.25	.060	#8 SCREW

HASPS	L1	L2	W1	W2	PIN DIAMETER	HOLE
135	3.34	1.34	.343	1.50	.187	.075
145	4.34	1.34	.343	1.50	.187	.075
160	6.00	2.75	.343	1.87	.187	.104