

## PANELOC Spring Latch Series Design Specifications

\*Designates dimensions that can be altered to meet your specifications.

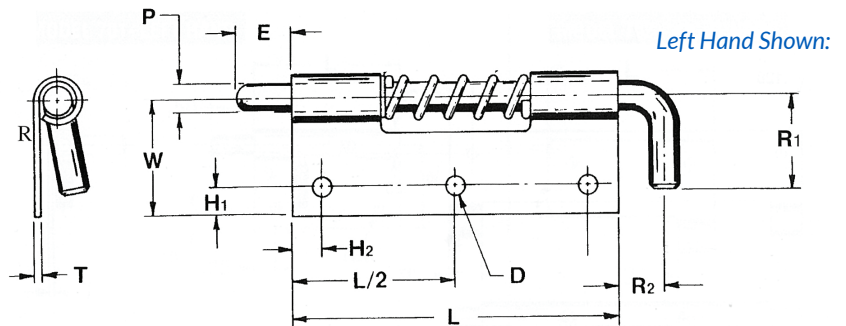

PART NUMBER      711      712      713      714      715      716      718      723

PIN		711	712	713	714	715	716	718	723
P	Pin Diameter	.125	.156	.187	.250	.187 SQ	.250	.375	.250
* E	Extension	.187	.250	.375	.500	.250	1.250	1.00	.625
* R1	Handle Length	.437	.625	.687	.812	.610	.720	1.50	.812
* R2	Handle Extension	.187	.250	.312	.375	.312	.375	1.50	.430

BODY		711	712	713	714	715	716	718	723
L	Length	.875	1.375	2.000	2.75	.875	3.50	4.00	2.75
* W	Width								
	A	.375	.500	.625	.75	.50	.720	1.50	.955
	B	.500	.750	.875	1.000	-	-	-	-
T	Thickness	.040	.040	.050	.060	.050	.060	.080	.090
* H1	Hole Location	.156	.187	.187	.250	.181	.281	.620	.400
* H2	Hole Location	.156	.187	.250	.250	.156	.750	.750	.375
* R1	Handle Length	.437	.625	.687	.812	.610	.720	1.50	.812
* R2	Handle Extension	.187	.250	.312	.375	.312	.375	1.50	.430

MATERIAL	Steel	Stainless Steel	Aluminum
Designation	S	C	A
Pin Type	12L14	303	SS
Body	1010	304	5052
Spring	302	302	302
C-Ring	PH15-7 MO	PH15-7 MO	PH15-7 MO

All springs and c-rings are made with stainless steel.

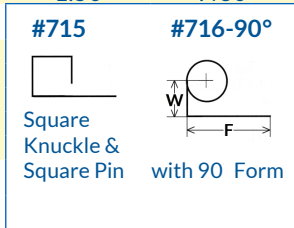

MODEL      R = Right Hand      L = Left Hand      U = Unassembled

POINT STYLE	1	2	3	4	5
Other styles available including long extensions					
	90° Cone	Ball	Bullet	Flat	60° Cone

FINISH  
Most commercial finishes are available including zinc plate on steel, passivate and electropolishing on stainless steel, and anodize on aluminum.

