

Spring Release Hinge Series 700

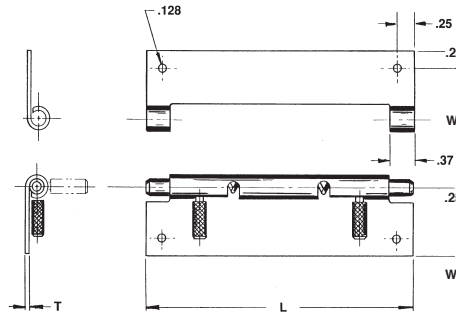

Combining a hinge and a latch in a standard piece of hardware.

The 700 Series Spring Release Hinge has a pair of spring-loaded handles which pull toward the center to release the body or door from the keeper. Installation is simple and inexpensive using screws, rivets or by welding.

All styles are manufactured to close tolerances. End play and side play are held to a minimum, insuring a precision fit and smooth operation.

This latch is ideally suited for applications including aircraft components, computer equipment, shelving & storage units, and medical equipment.

BODY

L Length	3"	4"	6"	Special
W Width	1"	1"	1"	-
T Thickness	.050	.050	.050	-
DASH #	-3	-4	-6	-7

PIN

P Pin Diameter	.250	Special
W Metal Thickness	.050	-
DASH #	-1	-

HOLES

	None	Standard (2 Holes)	Special
DASH #	-0	-1	-7

MATERIAL

	Aluminum	Steel	Stainless
DASH #	-1	-2	-3

MODEL

	Male	Female (Keeper)	Complete Assembly
	-1	-2	-A

FINISH

Most commercial finishes are available including zinc plate on steel, passivate and electropolishing on stainless steel, and anodize on aluminum.

ORDERING INFORMATION

Sample Part #

700 - 4 - 1 - 0 - 3 - A

Basic Part No.	↑	↑	↑	↑	↑	↑	Model (Complete Assembly)
Body	↑	↑	↑	↑	↑	↑	Material (Stainless Steel)
Pin (.250)	↑	↑	↑	↑	↑	↑	Holes (None)
Metal Thickness (.050)	↑	↑	↑	↑	↑	↑	